

Sugar Technologies

Advanced Planetary Know-how at your disposal



Since 1970 Dinamic Oil has been a leading global manufacturer of Hoisting Winches. These winches are complemented by a range of Planetary Gearboxes with output torques from 1,000 Nm to 4,000,000 Nm. Thanks to a continuous research and development Dinamic Oil is supplying innovative and reliable products to the most demanding industries.

This document shows many examples where Dinamic Oil has provided successful solutions in a variety of globally recognized Sugar Cane Applications.

dinamic oil

Sugar Technologies

For more than 10 years Dinamic Oil has been providing innovative custom solutions to the Sugar Industry. Dinamic Oil Planetary Gearboxes and Winches are successfully driving Cane Carriers, Feeder Tables, Pushers, Rack Carriers, Inter Rack and Bagasse Elevators, Bagasse Conveyors, GRPF, RBC (Return Bagasse Carrier), Wagon Tilters, and many other Sugar Cane Applications worldwide.



Single and Multiple Drive Mill Solutions

Dinamic Oil proposes innovative custom solutions for Sugar Cane Mills of any size and configuration.

Products Range

Dinamic Oil's great variety of sizes, configurations and accessories make our range suitable for all the Sugar Mill Applications.

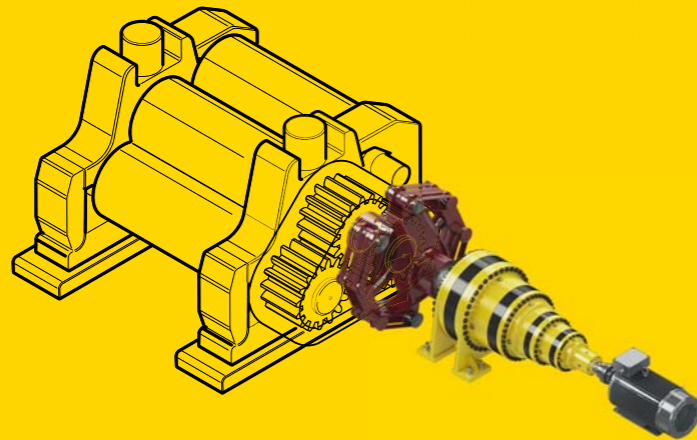

Model	T ₂ nom	T ₂ max
<i>GB</i>	<i>kNm</i>	<i>kNm</i>
85000	900	1500
110000	1150	2350
130000	1370	2950
150000	1850	4000
205000	2350	4100
235000	2650	4500
310000	3200	5350
410000	4600	7100

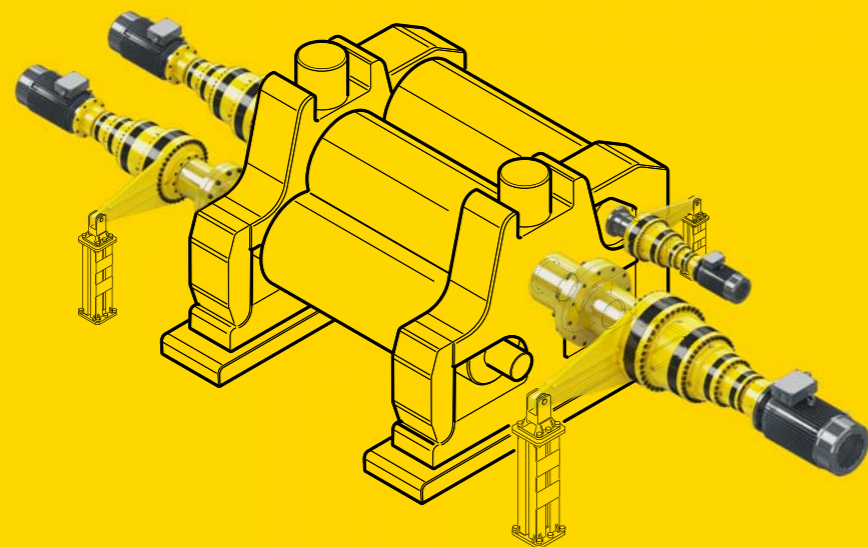

Sugar Mill Trains

As Main or Assist Drives, Dynamic Oil Gearboxes meet the demand of high torque and efficiency related to the cane grinding process.

Sugar Mill Diffusers

Dynamic Oil Planetary Gearboxes are the ideal Diffuser Drive solution, where the challenge is the reliability at high torque and low speed requirements.

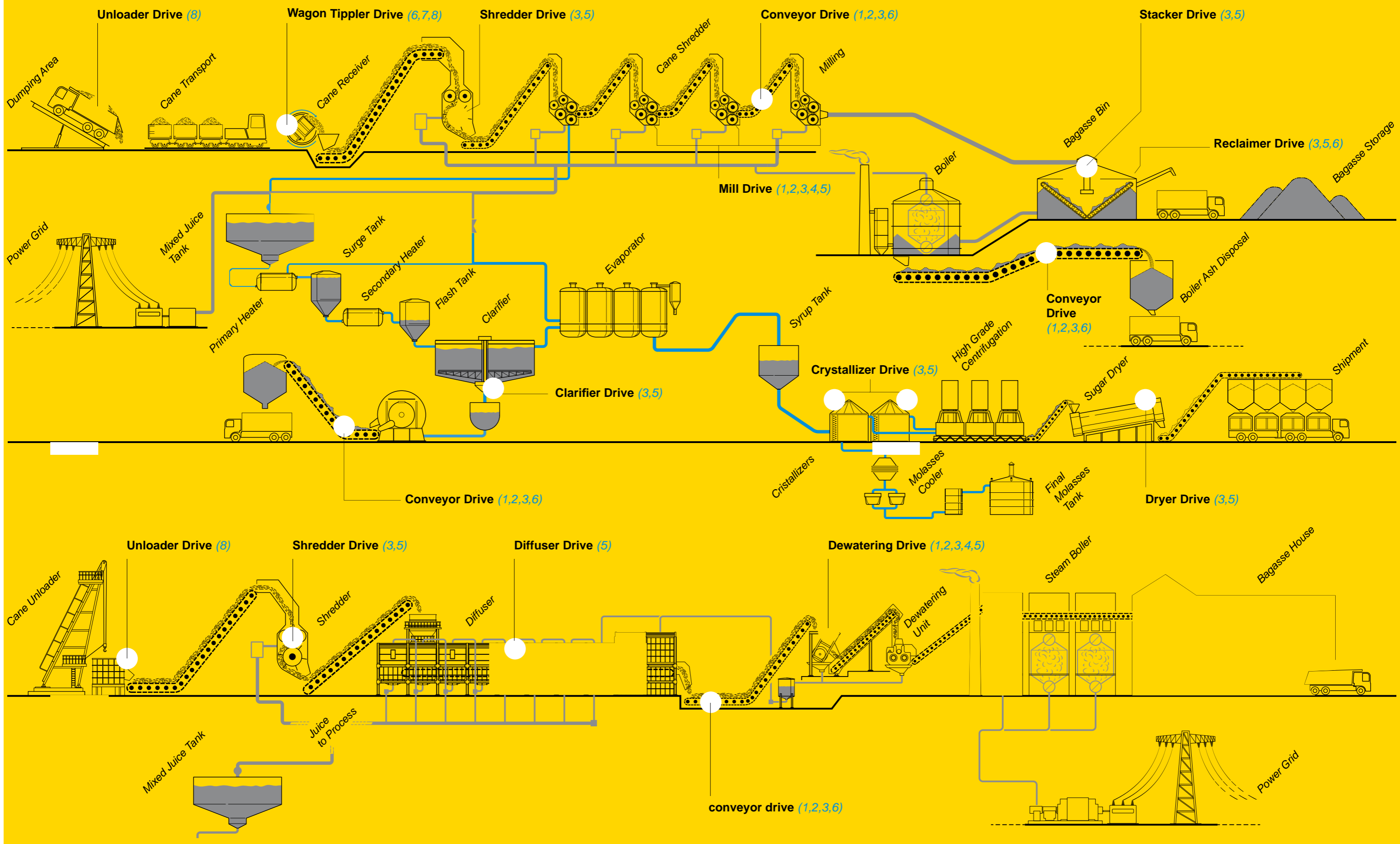

Branches

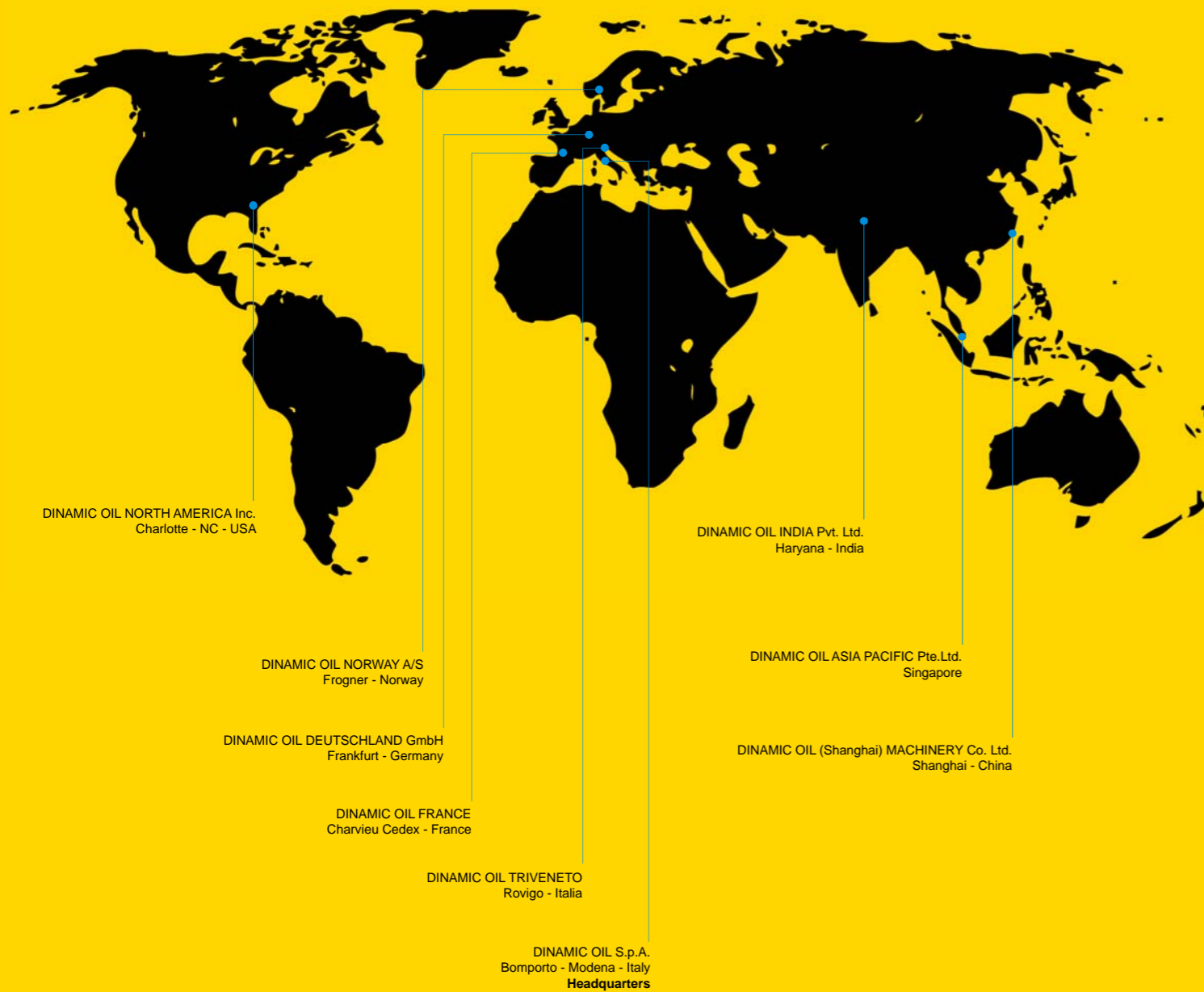

All the components are manufactured in the purpose built Italian factory and company headquarters; five subsidiaries around the world (USA, Norway, India, China, Singapore) are able to make assembling, test, customization and to provide after sales service and spare parts delivery.

dinamic oil

dinamicoil.com

ST16/A/EN

Dinamic Oil S.p.A.

Via Togliatti, 15
41030 Bomporto - MO - Italy
T: +39 059 812611
F: +39 059 812603
E: info@dinamicoil.it
dinamicoil.com

Dinamic Oil Deutschland GmbH

Frankfurt Straße 151 b
D - 63303 Dreieich-Sprendlingen
T: +49 (0) 6103 2024593
F: +49 (0) 6103 8077239
E: verkauf@dinamicoil.de
dinamicoil.com/deutschland

Dinamic Oil (Shanghai) Machinery Co., Ltd.

Building 2, N°128 Lane 168 Dieqiao Rd.
Kangqiao Industry Park Pudong
201319 Shanghai – China
T: 0086 21 6818 7100
F: 0086 21 6818 7107
E: info@dinamicoil.com.cn
dinamicoil.com/china

Dinamic Oil India Pvt. Ltd.

Plot No.5, Sector - 16 HSIDC
Industrial Area, Bahadurgarh
Pin Code: 124507, Haryana - India
T: +91 1276 605295, 605296
E: india@dinamicoil.com

Dinamic Oil Triveneto

Via Enrico Toti, 48
40500 Rovigo - Italy
T: +39 340 7745 664
F: +39 059 812603
E: a.coltro@dinamicoil.it
dinamicoil.com/triveneto

Dinamic Oil Norway A/S

Lindebergveien, 3
2016 Frogner - Norway
T: +47 63 82 50 40
F: +47 63 82 50 41
E: DinamicOil.Norway@dinamicoil.com
dinamicoil.com/norway

戴纳密克 (上海) 机械有限公司

中国上海浦东康桥工业园区
叠桥路168弄128号2栋1楼
邮编：201319
电话：0086 21 6818 7100
传真：0086 21 6818 7107
邮件：info@dinamicoil.com.cn
dinamicoil.com/china

Dinamic Oil France

ZI Montbertrand BP 3612
38236 Charvieu Cedex - France
T: +33 (0) 472 462 318
F: +33 (0) 472 462 327
E: dinamicoil@orange.fr
dinamicoil.com/france

Dinamic Oil North America Inc.

4725 Entrance Drive - Suite A
Charlotte - NC - 28273 - USA
T: +1 704 587 4600
F: +1 980 939 6297
E: info.usa@dinamicoil.com
dinamicoil.com/northamerica

Dinamic Oil Asia Pacific Pte. Ltd.

47L Tuas South Avenue, 1
637249 - Singapore
T: +65 6791 0802
F: +65 6791 2661
E: sales@dinamicoilap.com.sg
dinamicoil.com/asia

Dinamic Oil reserves the right to implement modifications without notice. This catalogue cannot be reproduced, even partially, without prior concert.
March 2016

Coordination:
Marketing Department Dinamic Oil
3D illustrations: Phil Studium, Modena
Print: B&B srl, Reggio Emilia
Photo Headquarter: Still Life.

Graphic and Design: Massimiliano Marrani
All rights reserved ©